

KOCAELI CHAMBER OF INDUSTRY

# PROSES

SAFETY SYMPOSIUM

Beyond Compliance: Unlocking the  
Value of Digital Functional Safety  
**Ramees Musthafa**

HIMA

8-9 OCTOBER 2024



**KOCAELI SANAYI ODASI**

K O C A E L I C H A M B E R O F I N D U S T R Y

# We have Safety Standards. At the same time...

## 2 Dead, 30 Hospitalized After 'Mass Casualty' Incident At LyondellBasell Chemical Plant Near La Porte

The incident comes just days after a leak at a Dow Chemical plant in La Porte, and another LyondellBasell leak in Galena Park.

Paul DeBenedetto / Katie Watkins | July 27, 2021, 10:06 PM (Last Updated: July 28, 2021, 7:28 AM)



2021



RE

La

kill

Hor

shz

Co

Du

for

che

## Safety lapses contributed to deadly Optima Plant explosion, report says



2020

A 2-mile radius shelter-in-place is went into effect after an explosion at the Chemours Dupont plant in Belle, W.Va. in 2020. (WSAZ with permission)

By Curtis Johnson

Published: Jul. 7, 2023 at 8:51 PM GMT+4

News

## Marathon refinery fire illustrates how industry goes quiet during a crisis

WWNO - New Orleans Public Radio | By Sara Sneath (DeSmog), Julie Dermansky (DeSmog)  
Published September 6, 2023 at 6:05 PM CDT



2023



## South Korean lithium battery fire kills 23 workers

Mike Head @MikeHeadWSWS  
© 25 June 2024

A terrible factory blaze, evidently ignited after battery cells exploded inside a lithium battery manufacturing plant, killed 23 mostly contract workers and injured eight more in Hwaseong, an industrial area just 50 kilometres of Seoul, the South Korean capital, on Monday.

2024



United States

## Valero's Texas City refinery hit by explosion, fire

By Erwin Seba

April 20, 2018 4:47 AM GMT+4 · Updated 6 years ago



2018

# World

## 3 dead in S Korea's Yeosu chemical factory blast

Fire broke out at 1.37 p.m. at a petrochemical manufacturing factory in the Yeosu Industrial Complex in Yeosu, 450 km south of Seoul

YANS | Seoul | December 13, 2021 5:24 pm



2021

# The Shortcomings of Traditional Methods in Functional Safety

## Lifecycle Complexity and Fragmentation



Information Silos  
Time-Consuming  
Error-Prone

## Documentation Inconsistencies

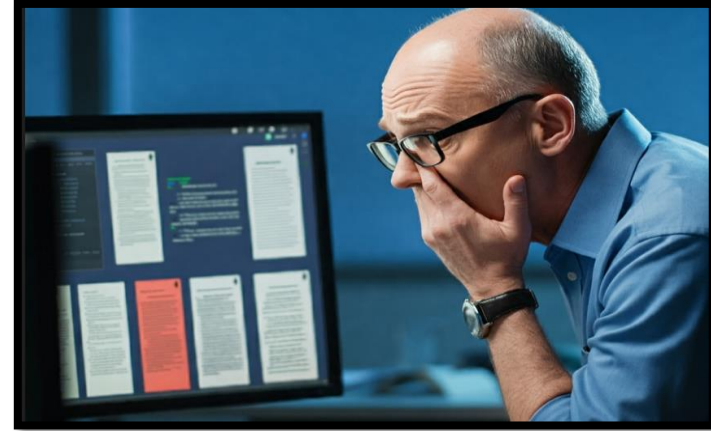

Compliance Challenge  
Impaired Maintenance and Modification

## Lack of Real-Time Insights

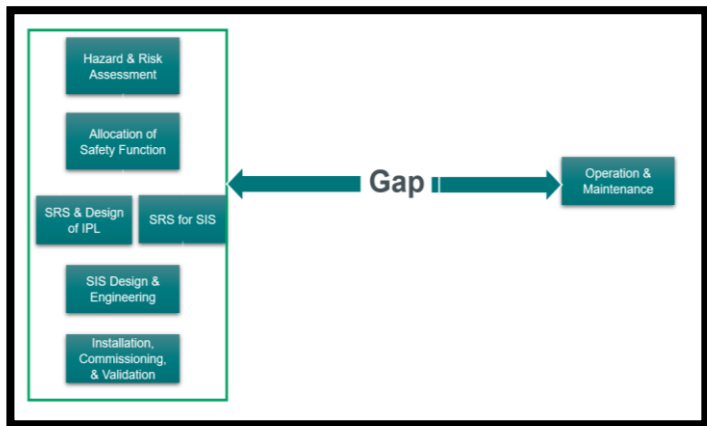

Limited Visibility  
Delayed/Wrong Decision Making

## Challenges in O&M activities

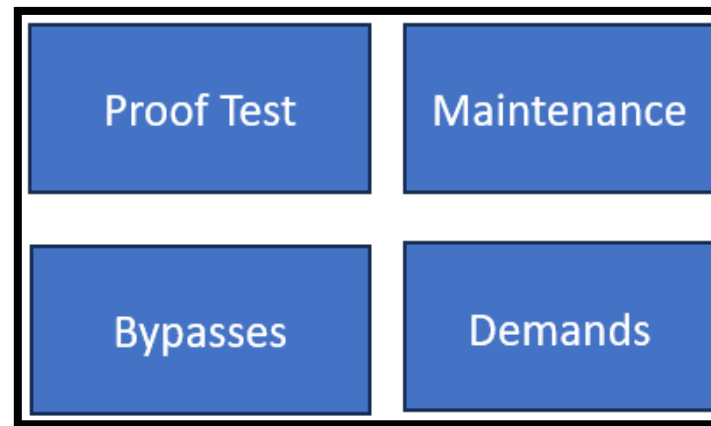

Spurious Trips  
Improper PT Management  
Bypass Management Issues  
Limited Data Analysis for Predictive Maintenance

# The Shortcomings of Traditional Methods in Functional Safety

## Lifecycle Complexity and Fragmentation



Information Silos  
Time-Consuming  
Error-Prone

## Documentation Inconsistencies



Compliance Challenge  
Impaired Maintenance and Modification

## Lack of Real-Time Insights

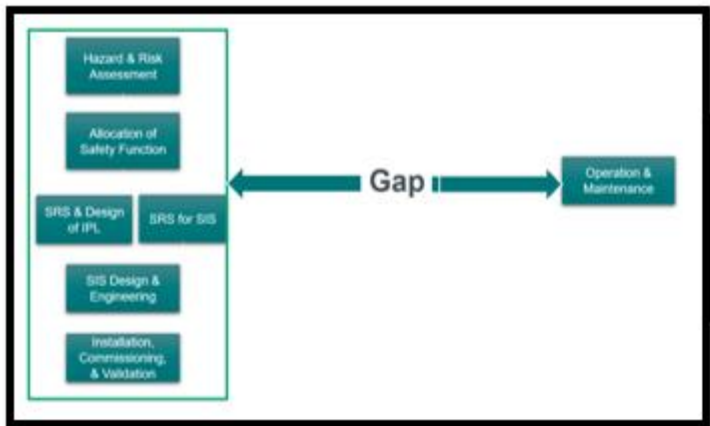

Limited Visibility  
Delayed/Wrong Decision Making

## Challenges in O&M activities

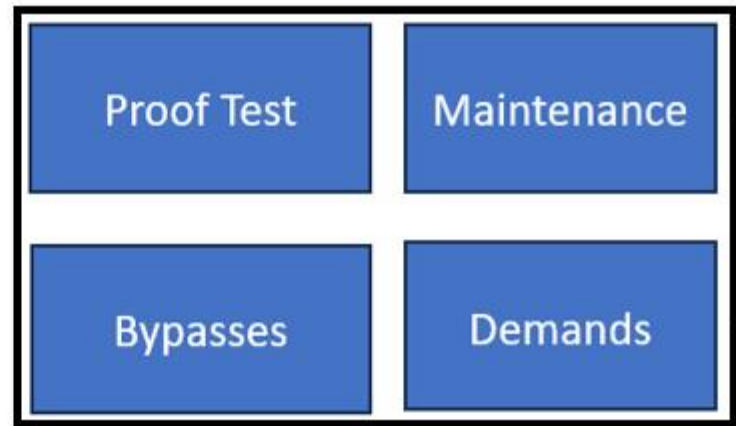

Spurious Trips  
Improper PT Management  
Bypass Management Issues  
Limited Data Analysis for Predictive Maintenance

# The Shortcomings of Traditional Methods in Functional Safety

## Lifecycle Complexity and Fragmentation



Information Silos  
Time-Consuming  
Error-Prone

## Documentation Inconsistencies



Compliance Challenge  
Impaired Maintenance  
and Modification

## Lack of Real-Time Insights

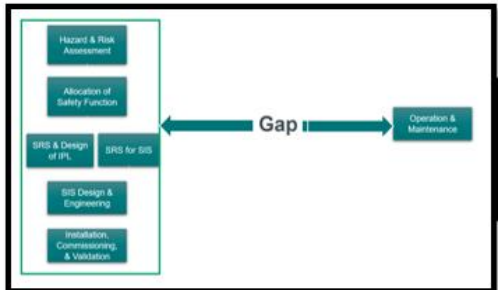

Limited Visibility  
Delayed/Wrong  
Decision Making

## Challenges in O&M activities

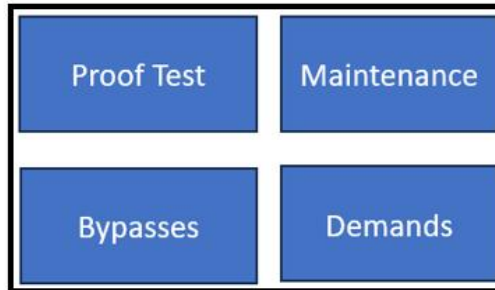

Spurious Trips  
Improper PT Management  
Bypass Management Issues  
Limited Data Analysis for  
Predictive Maintenance

Accidents

Downtime

Inefficiency

Reputational  
Damage

High Insurance  
Premiums

# The Solution : Digitalization of Functional Safety

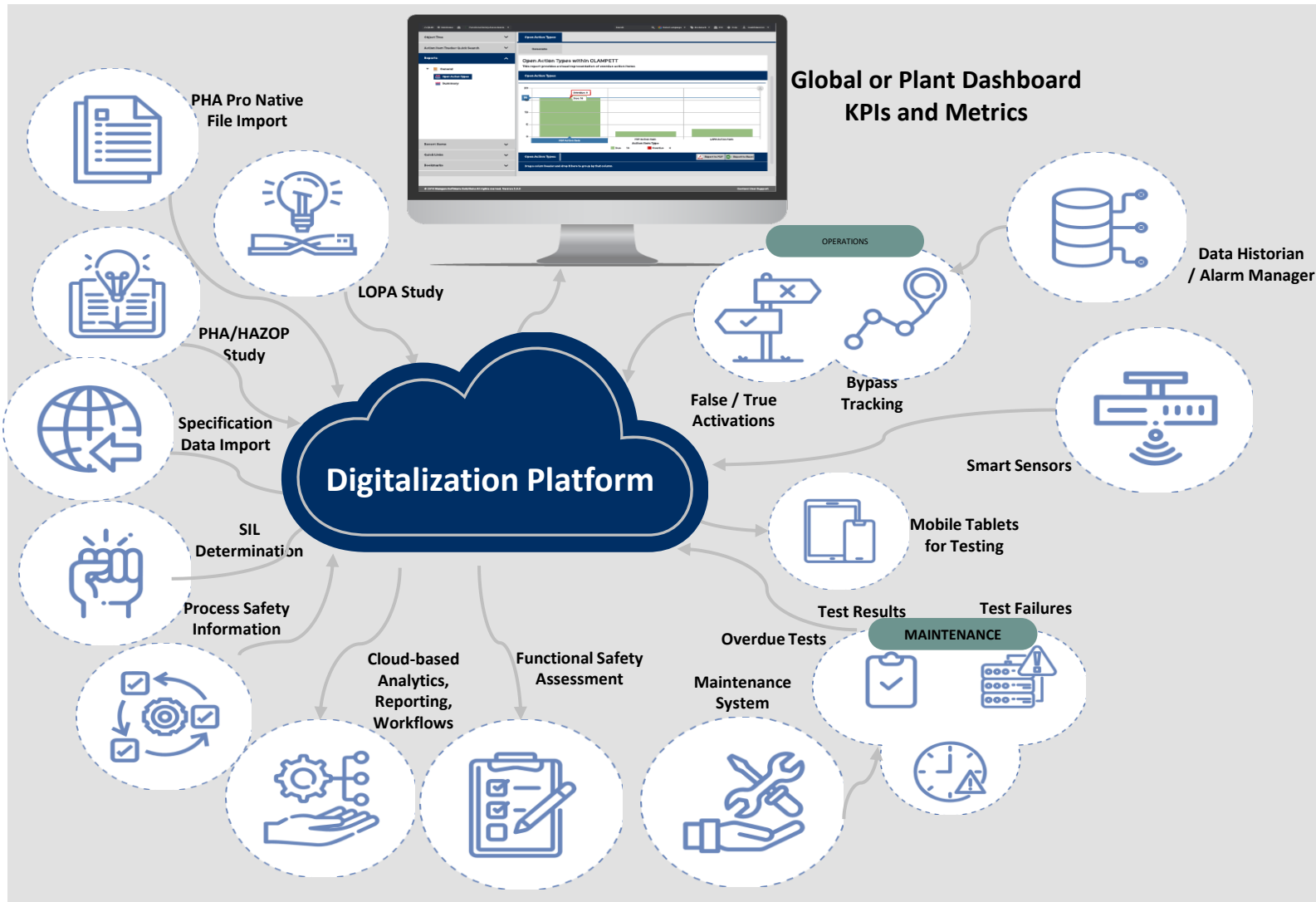

## Functional Safety Digitalization

Integration of various phases of safety lifecycle including design, implementation, operation and maintenance of safety instrumented systems (SIS) into a single digital platform.

# Digitalization Architecture- Generic

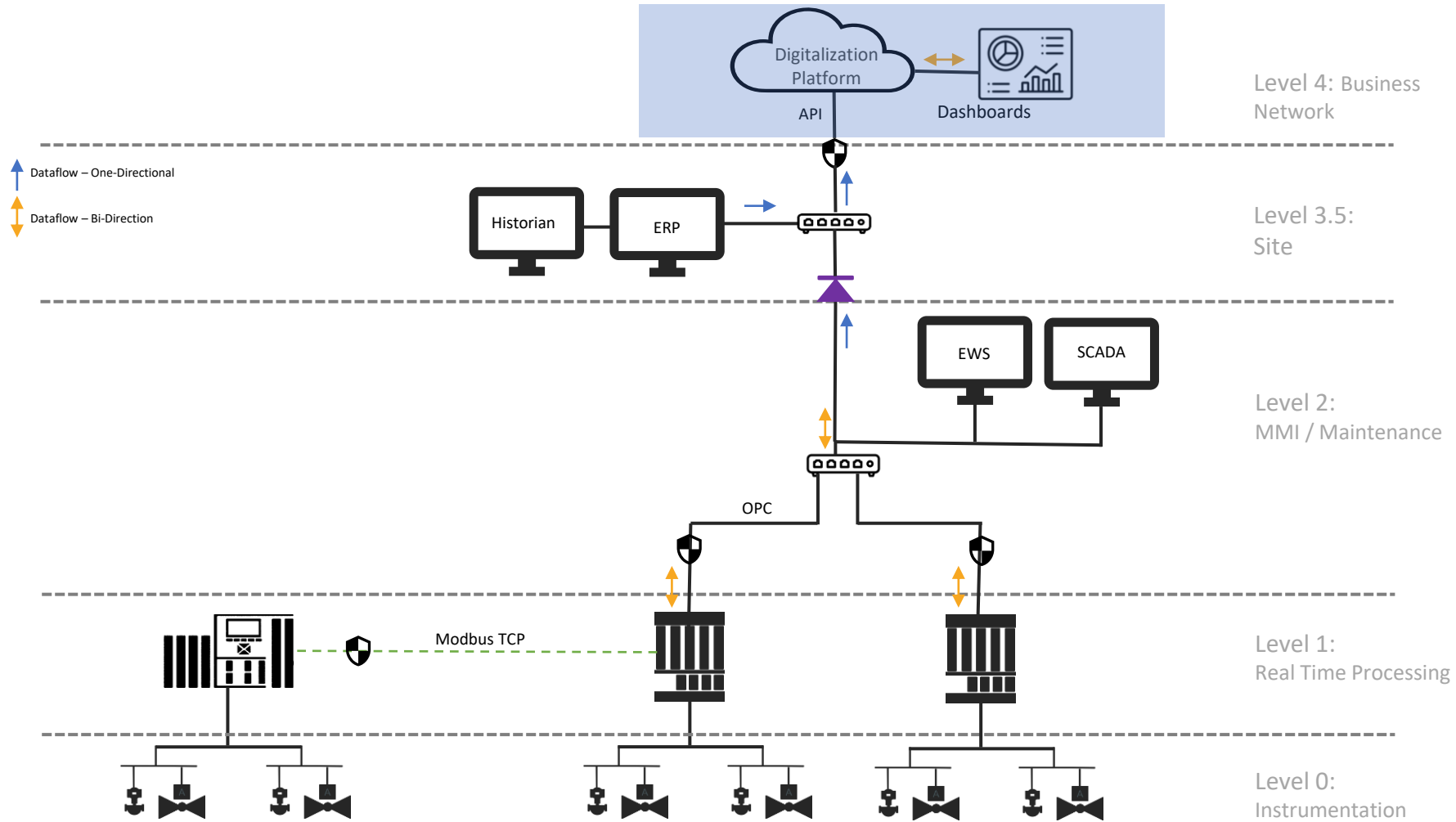

# Is Digitalization a “necessity” or “Luxury” ?

## Digitalization means...

Automation of FS Activities

Less Human Error

Tangible Compliance KPIs

Data-Driven Decision Making

Cost Optimization

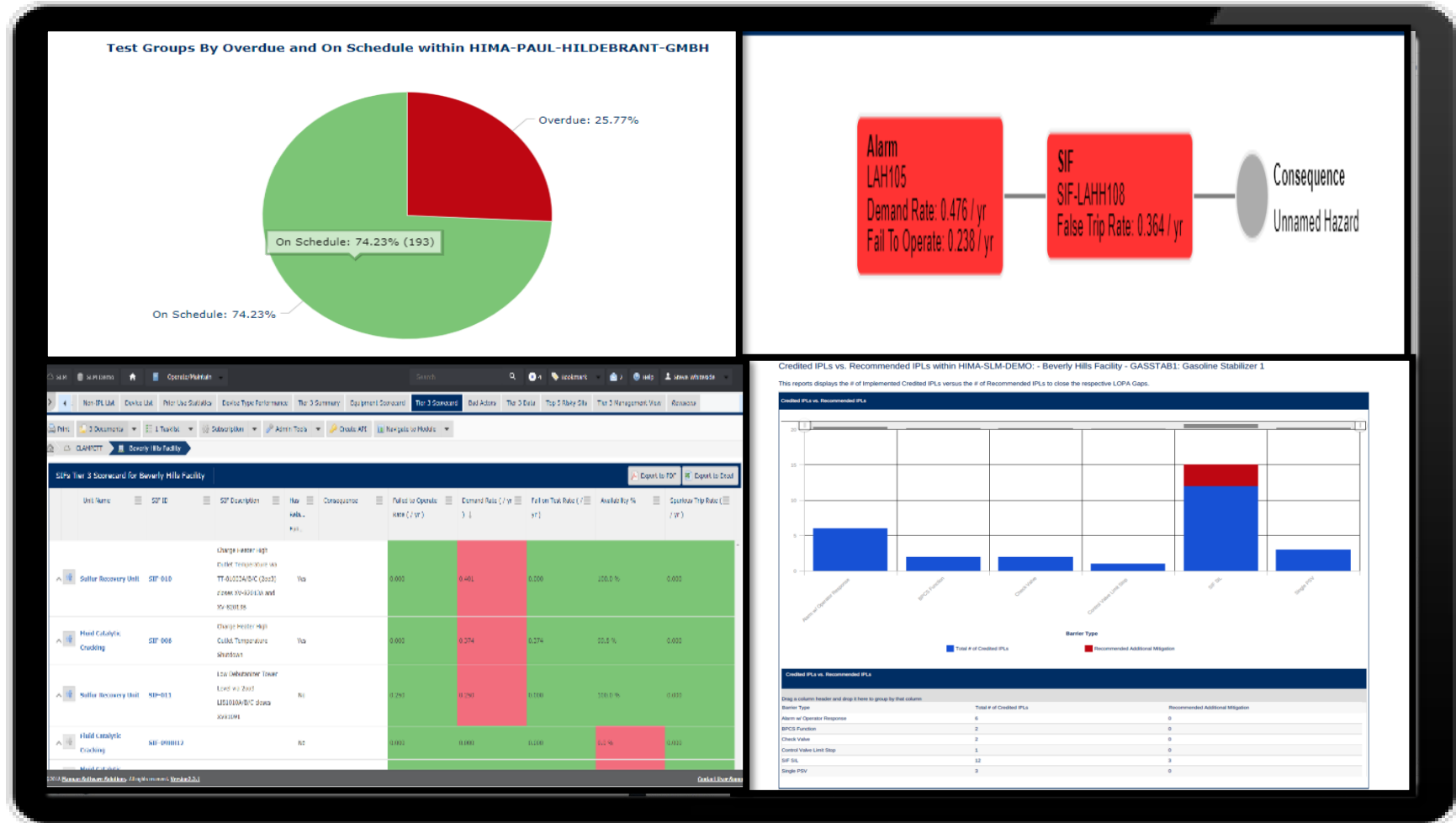



# Is Digitalization a “necessity” or “Luxury” ?

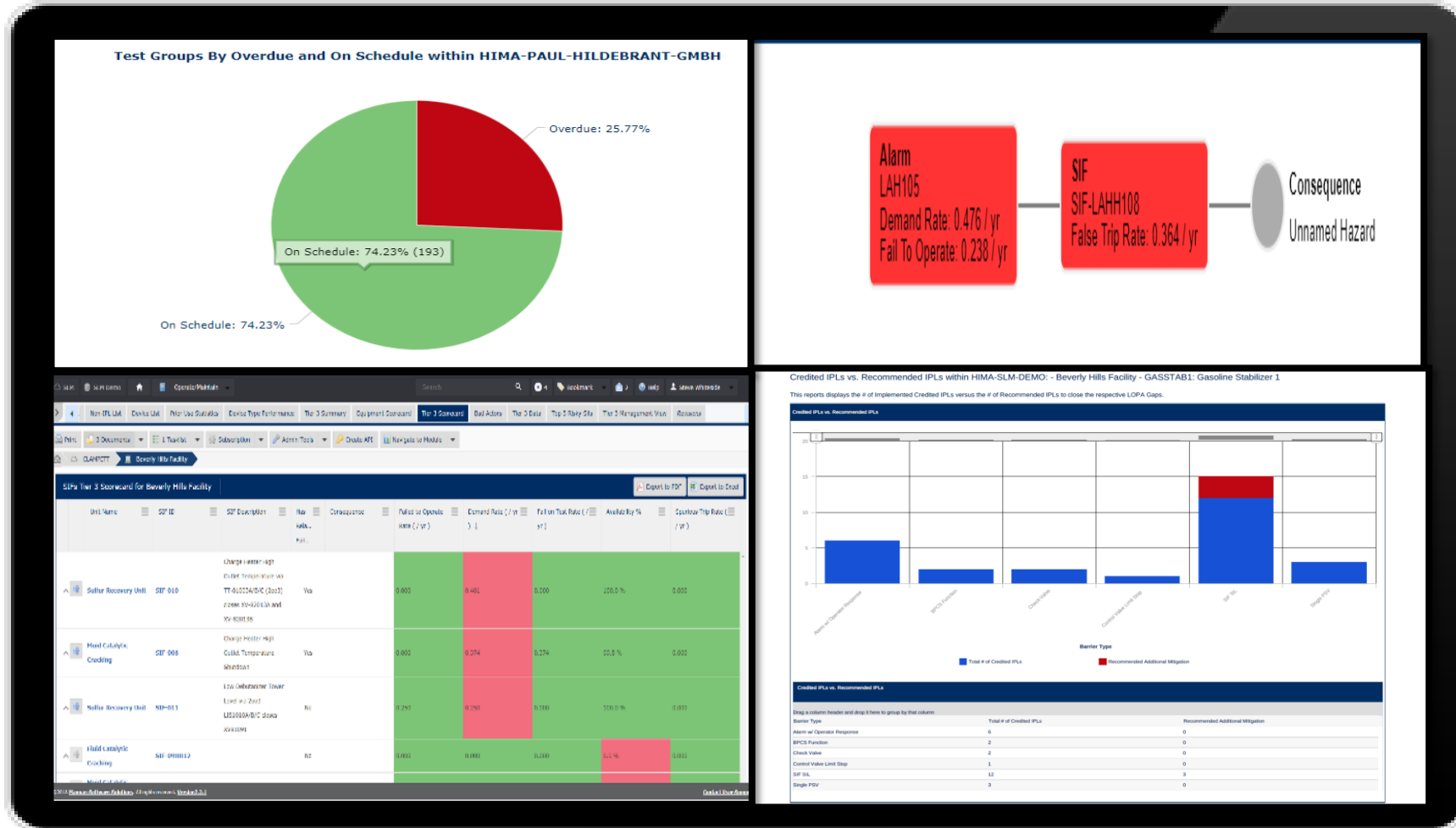

Plant Risk Reduction..

Spurious Trip Avoidance

Improved Efficiency

Improved Profitability

365 Days Compliance

High Reputation

# Increased Profitability ...?



SIFs

200

Voting

100%

Proof Test

1 YEAR

FS Activities



Annual Premium

1M

Accident Claim

10 MILLION



- Reduced Proof Testing Time **➤** 90% **↓** **➤** 367 Hrs Savings for 200 Valves, for a team of 10 → 36.7 Prod Hrs
- Improved Team Efficiency **➤** 50% **↑** **➤** 1560 Hrs Savings → Reduction in manpower needed for testing
- Documentation Efficiency **➤** 65% **↑** **➤** 520 Hrs Savings due to reducing manual reporting effort
- Insurance Premium Reduction **➤** 7.5% **↓** **➤** 75,000 \$ savings / Year  
\*\*improved Risk Transparency & Safety Performance Monitoring
- Enhanced Claim Defense **➤** 15% **↑** **➤** 1,500,000 \$ /Accident  
\*\*Avoidance of reduced insurance payouts
- Enhanced Operational cycle **➤** 3% **↑** **➤** Extending proof test interval by 6 months without breaching SIL

# Choosing the Right Digitalization Partner

When selecting the right solution for functional safety digitalization in your process plant, several critical factors should be considered such as:



**Cost-Efficiency and ROI**



**Scalability and Flexibility**



**Cybersecurity**

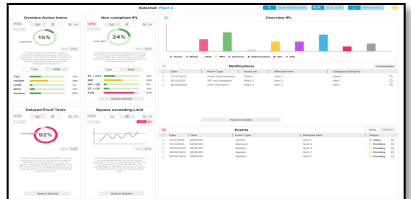

**Advanced Data Analytics and Reporting Capabilities**

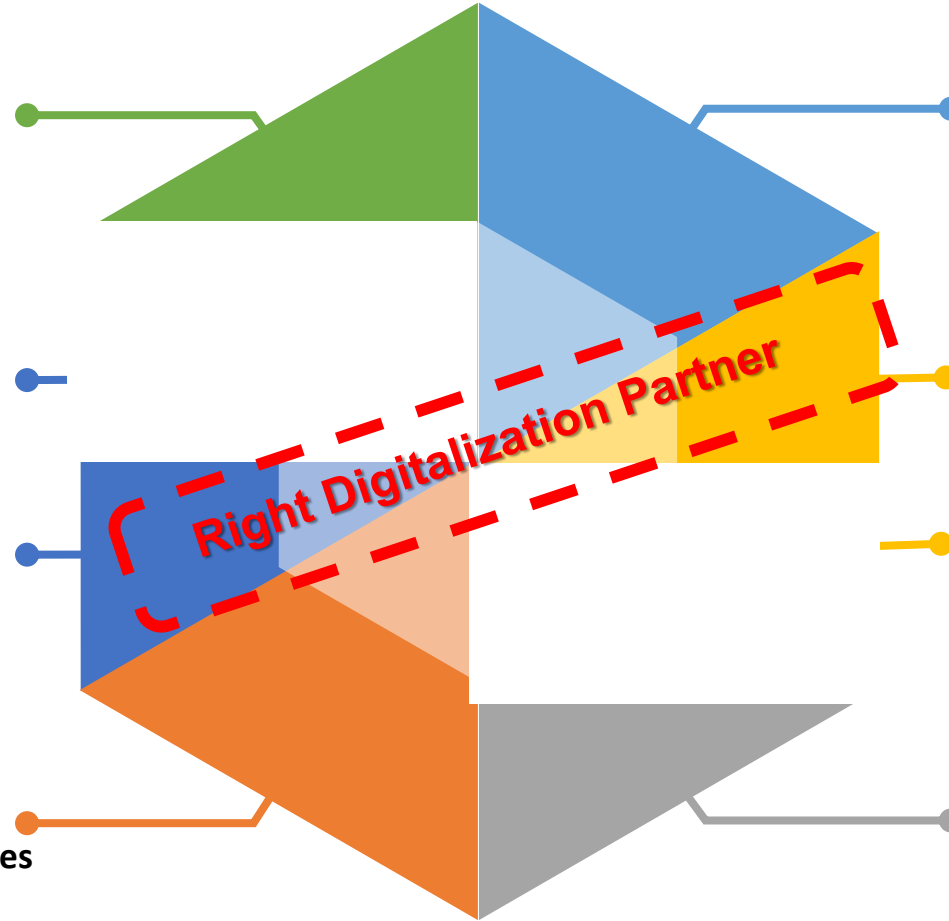

**Certified for Standards (IEC 61508/61511)**



**Integration with Existing Systems**



**Ease of Use and Training**



**Expertise and Proven Track Record**



## With Functional Safety Digitalization

We ~~think~~ we are safe..  
**know**

KOCAELI CHAMBER OF INDUSTRY

**PROSES**  
SAFETY SYMPOSIUM

**FUAR İÇİ 41040 IZMIT/KOCAELİ**

**TEL: +90 262 315 80 00**

**FAX: +90 262 321 90 70**

**WEB: [www.kosano.org.tr](http://www.kosano.org.tr)**

**E-MAIL: [kso@kosano.org.tr](mailto:kso@kosano.org.tr)**

